



**MITSUBISHI ELECTRIC AUTOMATION (THAILAND) CO., LTD.**

Bang-Chan Industrial Estate No. 111 Moo 4, Serithai Rd., T.Kannayao, A.Kannayao, BKK 10230 Thailand  
Tel: (66) 2517-1326, (66) 2919-9873 Fax: (66) 2517-1328 URL: www.meath-co.com E-mail: support@meath.co.th

**บริษัท มิตซูบิชิ อิเล็กทริก ออโตเมชัน (ประเทศไทย) จำกัด**

นิติบุคคลสาขารวมบางชั้น เลขที่ 111 หมู่ 4 ถนนเสรีไทย แขวงคันนายาว เขตคันนายาว กทม. 10230

โทรศัพท์: (66) 2517-1326, (66) 2919-9873 โทรสาร: (66) 2517-1328 URL: www.meath-co.com E-mail: support@meath.co.th

**MOTOR SPECIFICATION SHEET**

MODEL : SF-PRO 55kW 4P  
USED FOR : 380V 50Hz  
MANUFACTURER : MITSUBISHI ELECTRIC CORPORATION

DESCRIPTION	DETAIL
PHASE	3
MODEL NAME	SF-PRO
RATED OUTPUT	55 kW
POLE	4
CODE	MEATH CODE : 1MU00F-405500LJLT0
OUTLINE DRAWING NO.	BD39534-*
RATED VOLTAGE (V)	380
RATED FREQUENCY (Hz)	50
RATED CURRENT (A)	105
RATED SPEED (min <sup>-1</sup> )	1480
RATED EFFICIENCY	95.5%
EFFICIENCY CLASS	IE3
THERMAL CLASS	155 (F)
RATING	S1 (CONTINUOUS)
ENCLOSURE CONSTRUCTION	TOTALLY ENCLOSED FAN COOLED
DEGREES OF PROTECTION	IP44 (OUTDOOR WATERPROOF)
METHOD OF COOLING	IC411
FRAME NO.	225S
WEIGHT (kg)	380
STANDARD	JIS C 4213, JEC-2137-2000
INSTALLATION	FOOT MOUNTED
ROTATION	CCW (VIEWED FROM SHAFT END)
BEARING	LOAD SIDE : 6315ZZ OPPOSITE SIDE : 6312ZZ
BEARING GREASE	UREA GREASE
NOISE (dB.A)*	73
VIBRATION	V15
CIRCUMSTANCE CONDITION	AMBIENT TEMPERATURE : -30 ~ +40°C AMBIENT HUMIDITY : 100% RH (NO CONDENSATION) ABOVE SEA LEVEL : 1000m OR BELOW ENVIRONMENT : NO CORROSIVE/EXPLOSIVE GAS, NO STEAM OR CONDENSATION, MINIMAL DUST.
COLOR	MUNSELL N7 (GRAY)
TERMINAL BOX	NO. OF LEAD WIRES : 6 ** SOURCE CONNECTION : LEAD WIRES
SHAFT SWING	≤0.05mm
MATERIAL	FRAME : STEEL PLATE BRACKET : CAST IRON SHAFT : CARBON STEEL STATOR CORE : ELECTRICAL STEEL WIRE : ENAMELLED COPPER MAGNET WIRE ROTOR CORE : ELECTRICAL STEEL CONDUCTOR : ALUMINIUM TERMINAL BOX : CAST IRON PAINTING : POLYURETHANE RESIN
PRODUCTION COUNTRY	JAPAN

\*Value indicates representative value, not guaranteed value.

\*\*Motor have total 12 lead wires, but only 6 lead wires are used for source connection.

Specifications subject to change without notice.

<b>SPECIFICATION SHEET NO.</b>				
SS-M-4617-B				

# TYPE SF-PRO SUPER-LINE THREE PHASE INDUCTION MOTOR

OUT LINE  
DIMENSION IN mm

OUTDOOR USE TYPE

TOTALLY ENCLOSED FAN COOLED  
PROTECTION DEGREE IP44 , COOLING METHOD IC411  
FRAME NO. 225S

CUSTOMER \_\_\_\_\_  
USER \_\_\_\_\_  
FOR \_\_\_\_\_  
CUST'S ORDER NO. \_\_\_\_\_  
QUANTITY \_\_\_\_\_ UNIT (S) \_\_\_\_\_  
MFG ORDER NO. \_\_\_\_\_

YOUR ORDER	kW · POLES	VOLT	HERTZ	MASS kg/UNIT	STYLE NO.
	55kW 4P	380V	50Hz	380	

IE Code-Rated Eff		
55kW	4P	IE3-95.5%

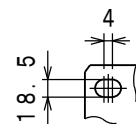
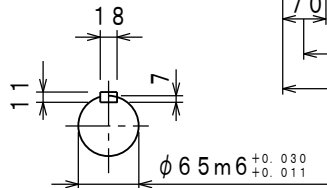
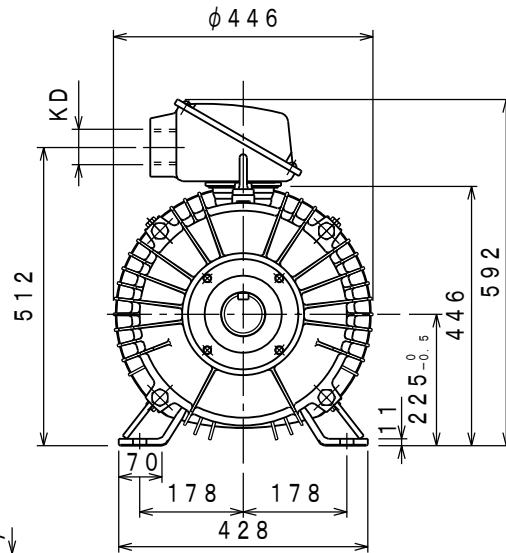
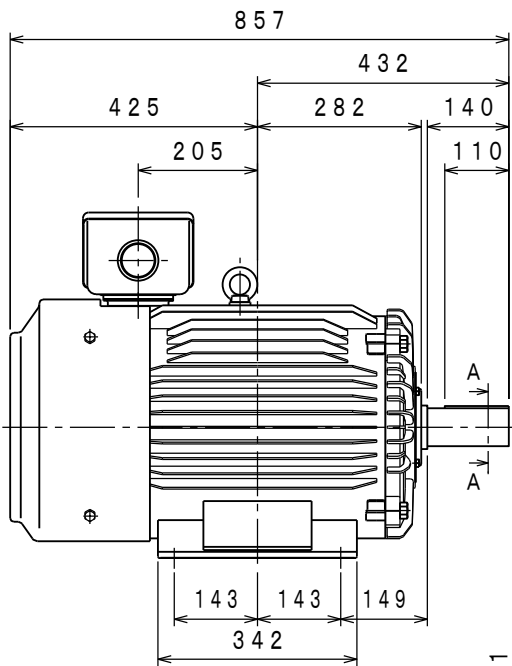

SECTION AA

PLANE VIEW OF FOOT

RATING	TH. CLASS	AMB. TEMP	BEARINGS		NO. OF TERMINALS	VIEWED FROM DRIVE END		COLOUR	KD
			LOAD SIDE	OPPOSITE SIDE		DIRECT. OF TERMINAL BOX	ROTATION		
S1	155 (F)	40° C	6315ZZ	6312ZZ	6	A (LEFT)	CCW	MUNSELL N7	PF2 1/2 SCREW

	DRAWN	APPROVED
SCALE NTS		
DATE MAR. 22. '19		

MITSUBISHI ELECTRIC CORP., JAPAN  
NAGOYA WORKS

CHANGE			

図面  
番号  
NO. **BD39534-\***

CAD(2D)